

This drawing is for spatial consideration only. Do not pre-plumb to these dimensions.

NOTES

1. INLET IS 5" PIPE (150# FLANGE)
2. OUTLET IS 5" PIPE (150# FLANGE)
3. MAXIMUM PRESSURE: 150 psi @ 250 Deg. F
4. SPECIFIED FLOWRATE OF 310 to 710gpm
5. PURGE IS 1-1/2" PIPE (NPT THREAD)
6. ASME CODE

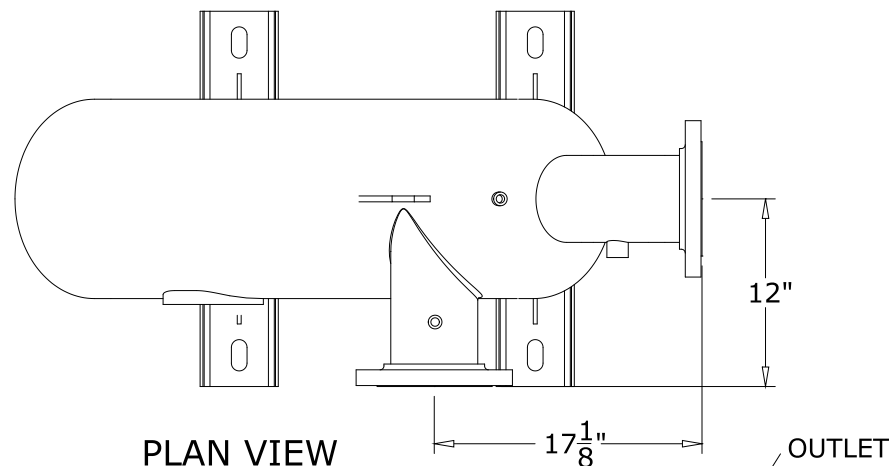

PLAN VIEW

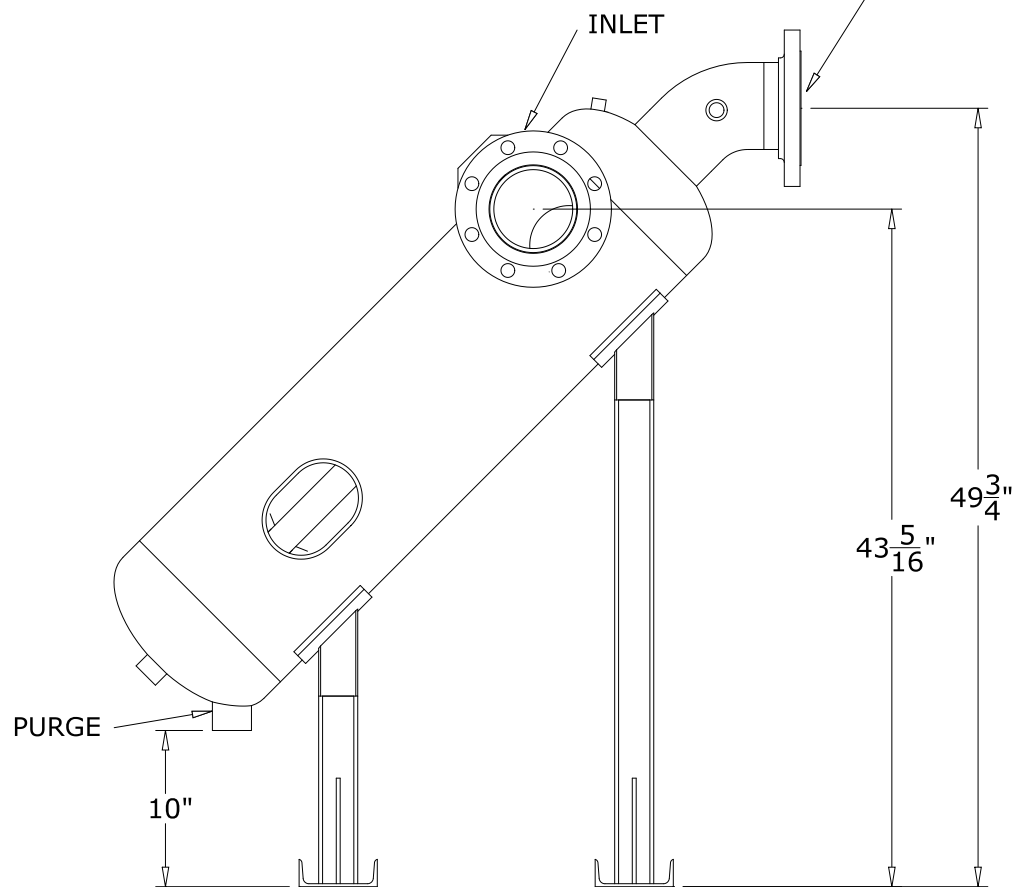

ELEVATION VIEW

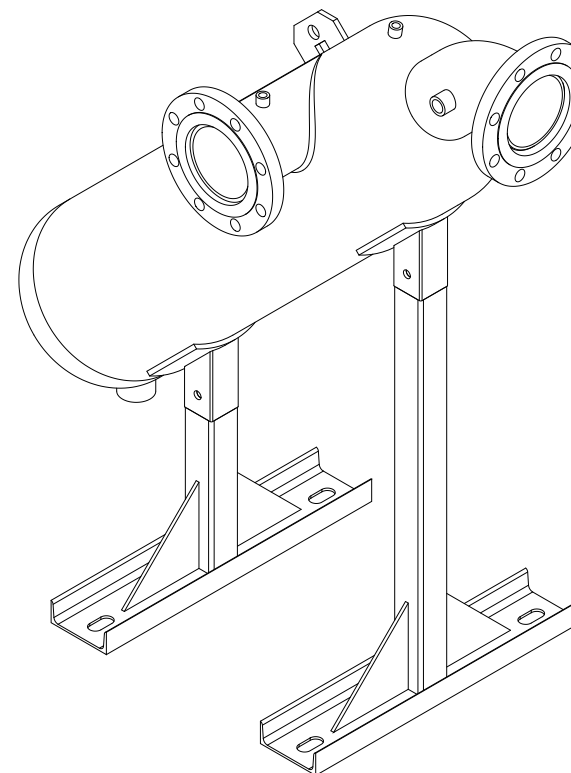

THIS DOCUMENT MAY CONTAIN PROPRIETARY INFORMATION. IT MAY NOT BE REPRODUCED OR TRANSFERRED TO OTHERS OR USED FOR MANUFACTURING OR ANY OTHER PURPOSE WITHOUT PRIOR WRITTEN PERMISSION.

GRISWOLD WATER SYSTEMS
1597 INDUSTRIAL DRIVE, NEW SMYRNA BEACH, FL 32168

CS-5T-LPA

DRAWN	-	DATE	-	MATERIAL:	DRAWING NO.	SIZE	REV.
APPRD	-		-	CARBON STEEL	-	A	-
				WEIGHT:300lbs. (136 kg.)	SCALE		SHEET 1 OF 1