

## AUTOMATED PURGE SYSTEM CYC TIMER OPERATION SETTINGS

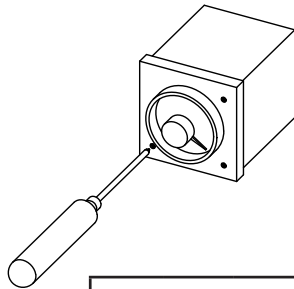
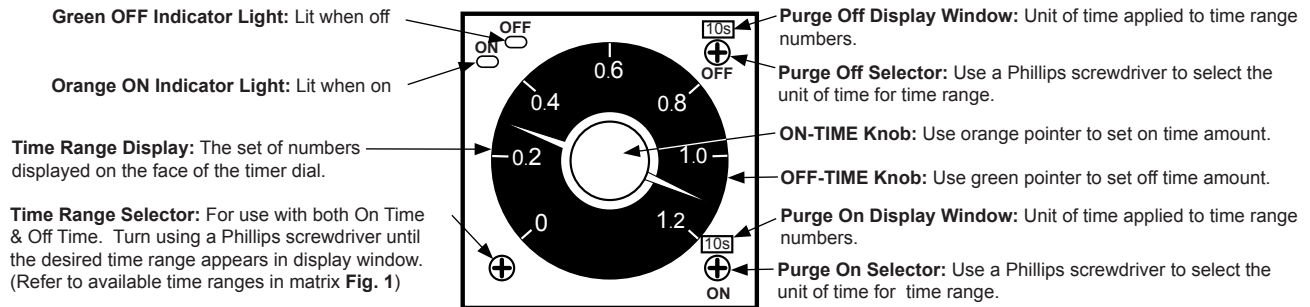

TIME RANGE	TIME UNITS			
	x10s (10 sec)	x10m (10 min)	h (hrs)	x10h (10 hrs)
0-1.2	1.2 to 12	1.2 to 12	0.12 to 1.2	1.2 to 12
0-3	3 to 30	3 to 30	0.3 to 3	3 to 30
0-12	12 to 120	12 to 120	1.2 to 12	12 to 120
0-30	30 to 300	30 to 300	3 to 30	30 to 300

**FIG. 1**

	MOTORIZED BALL VALVE (STANDARD)				MOTORIZED BALL VALVE SPRING RETURN (OPTIONAL)				MOTORIZED BALL VALVE FAIL SAFE (OPTIONAL)					
Separator	1/2"-3"	4"-6"	8"-12"	14"-20"	Separator	1/2"-3"	4"-6"	8"-12"	14"-20"	Separator	1/2"-3"	4"-6"	8"-12"	14"-20"
Purge Outlet	1"	1-1/2"	2"	3"	Purge Outlet	1"	1-1/2"	2"	3"	Purge Outlet	1"	1-1/2"	2"	3"
Factory Setting*	8/4/8	6/5/6		25/0/25	Factory Setting	55/0/15	150/0/15			Factory Setting	7/7/7		12/0/12	30/0/30
Time Range	0-1.2			0-12	Time Range	0-12	0-30			Time Range	0-30	0-1.2	0-30	
Purge OFF	10h			hrs	Purge OFF	hrs				Purge OFF	hrs	10h	hrs	
Purge ON	10s				Purge ON	10s				Purge ON	10s			
OFF-Time	.4			4	OFF-Time	4				OFF-Time	4	.4	4	
ON-Time	1.2	1.1		2.5	ON-Time	6	15			ON-Time	1.4	1.2	3	
Approx. Gal/Purge	2.70	6.35	9.60	48.04		7.86	43.66	71.96	158.54		3.15	7.41	10.47	57.65

\*SECONDS OPEN/DURATION/CLOSE

### BASIC SETTING OF SELECTOR:

- The selectors can be turned clockwise and counterclockwise to select the desired time unit, and time range.
- The desired time range is selected with the Time Range Selector at the lower left corner of the front panel. Use a Phillips screwdriver at the Time Range Selector until the correct range is displayed. Available time ranges are 0-1.2, 0-3, 0-12, 0-30. Factory default range is 0-1.2 for up to 2" purge valves as displayed above. Please refer to matrix above for specific settings and time ranges GF recommends.
- The desired time unit for Purge Off is selected with Purge Off Selector at the upper right corner of the front panel. Use a Phillips screwdriver at the Purge Off Selector until the correct time unit is displayed. Available time units include seconds, minutes hours, 10 hours. Factory default time unit is 10s as displayed above.
- The desired time unit for Purge On is selected with Purge On Selector at the lower right corner of the front panel. Use a Phillips screwdriver at the Purge On Selector until the correct time unit is displayed. Available time units include seconds, minutes hours, 10 hours. Factory default time unit is 10s as displayed above.
- Use the On Time and Off Time knobs to place the pointers at the desired time amount. Factory default for a motorized ball valve Off Time up to 2" is 0.4. Factory default for a motorized ball valve On Time is 1.2 for 1", 1.1 for 1.5" – 2". Please refer to the matrix above for information on setting the Time Units and Time Ranges for your specific purge valve.

## AUTOMATED PURGE SYSTEM VALVE INSTALLATION (CONT'D.)

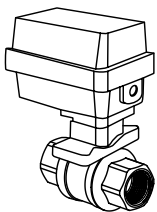
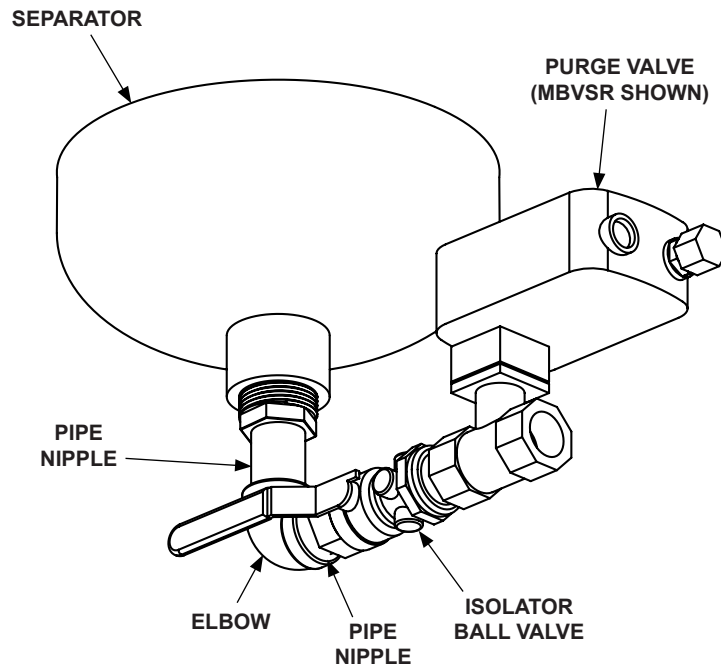

**MBV Valve:** The MBV Valve is an electrically operated 115VAC normally closed motorized ball valve. The actuator is permanently lubricated. The valve comes equipped with a manual override stem. If power ceases to exist while valve is open, then it will remain open until closed manual or power is restored. If power ceases to exist while valve is closed, then it will remain closed.

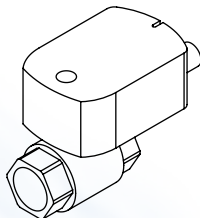

**MBVSR Valve:** Motorized ball valve. Normally closed. Requires power to open and power to close. If opened during a power outage, the valve will close.

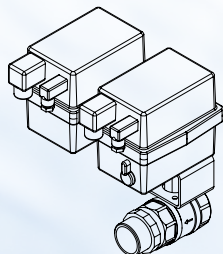

**MBVFS Valve:** The MBVFS is a motorized ball valve with battery pack. It is constructed from 316 stainless steel with Teflon seal. The valve requires power to open and close. Actuator includes failsafe self-rechargeable battery pack for fail-safe close on power loss. Battery pack requires 24 hrs charge before operation.

### CYC WIRING DIAGRAM WITH MBV VALVE (120V/1PH Auto Purge Systems Only)

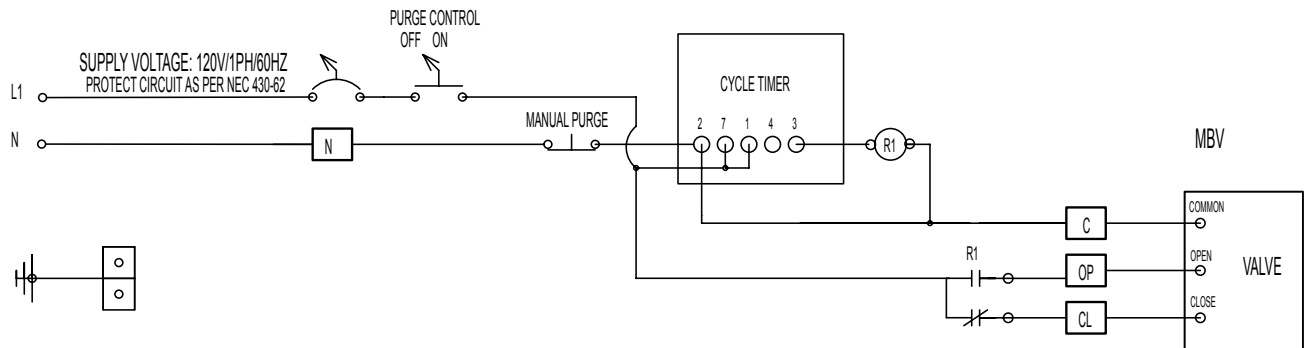

### CYC WIRING DIAGRAM WITH MBVSR VALVE (120V/1PH Auto Purge Systems Only)

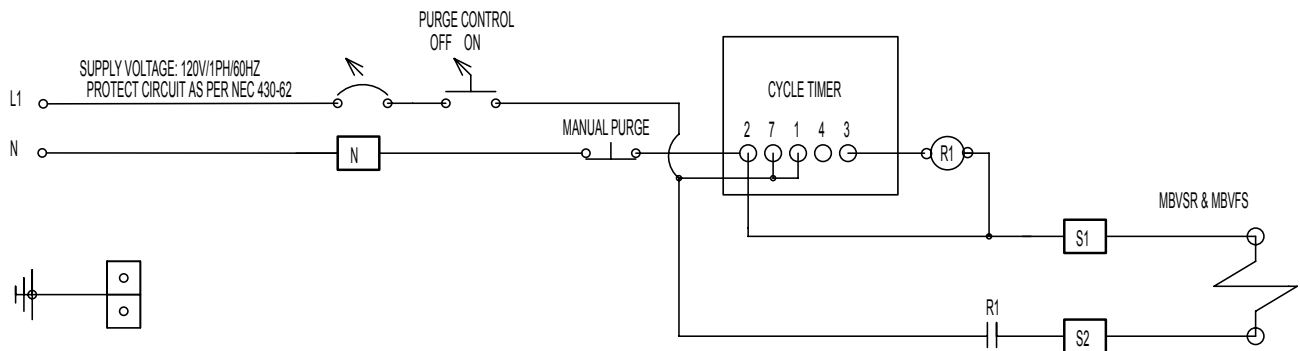

### CYC WIRING DIAGRAM WITH MBVFS VALVE (120V/1PH Auto Purge Systems Only)

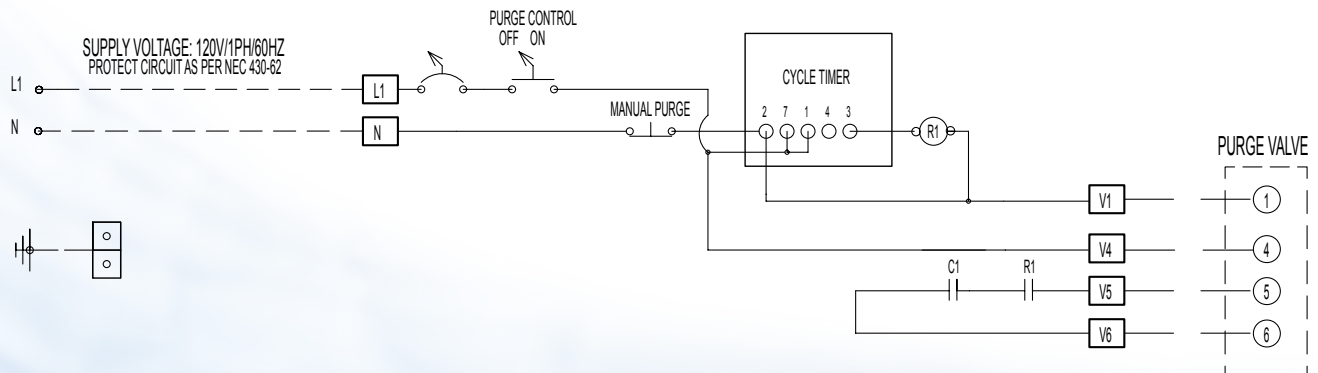

## CYC WIRING DIAGRAM WITH MBV VALVE (230V/1PH Auto Purge Systems Only)

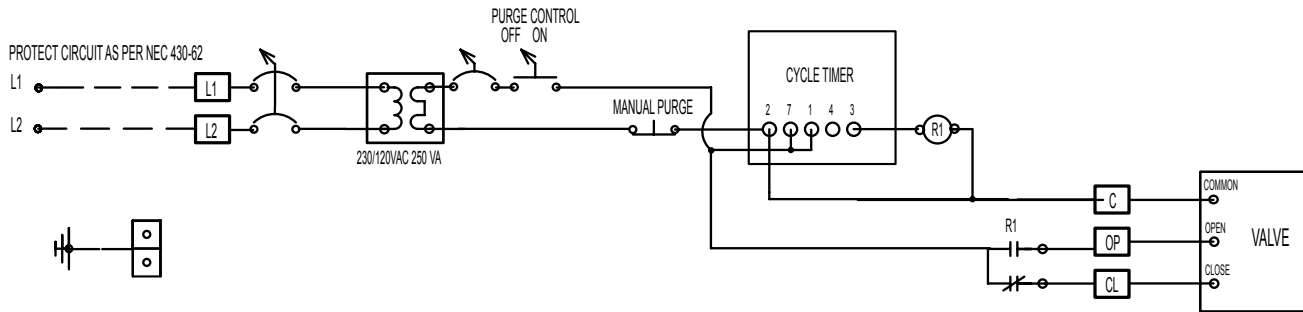

## CYC WIRING DIAGRAM WITH MBVSR VALVE (230V/1PH Auto Purge Systems Only)

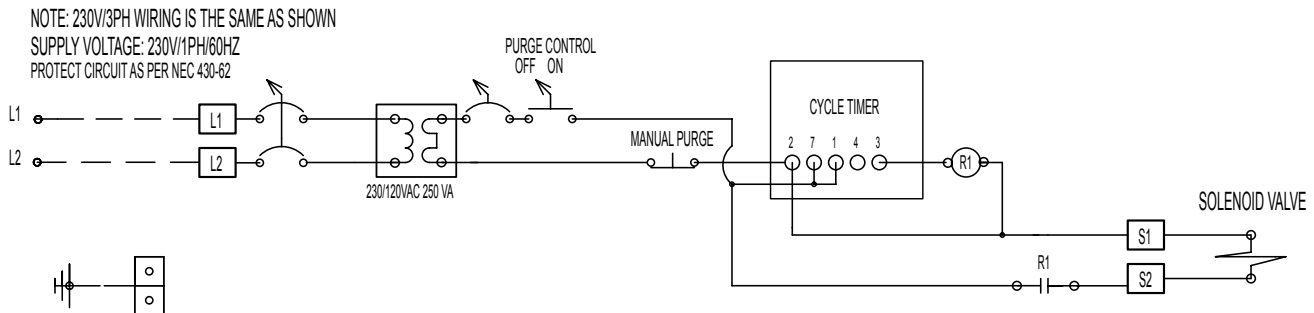

## CYC WIRING DIAGRAM WITH MBVFS VALVE (230V/1PH Auto Purge Systems Only)

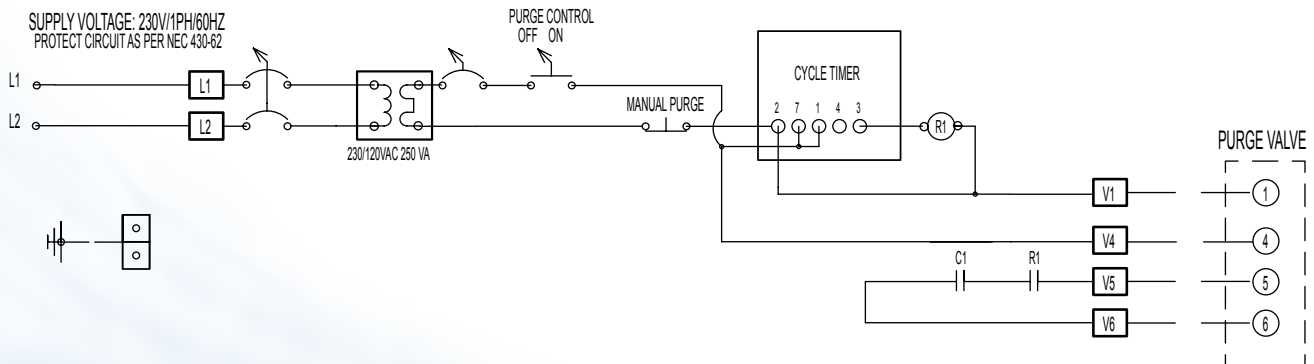

## CYC WIRING DIAGRAM WITH MBV VALVE (460V/1PH Auto Purge Systems Only)

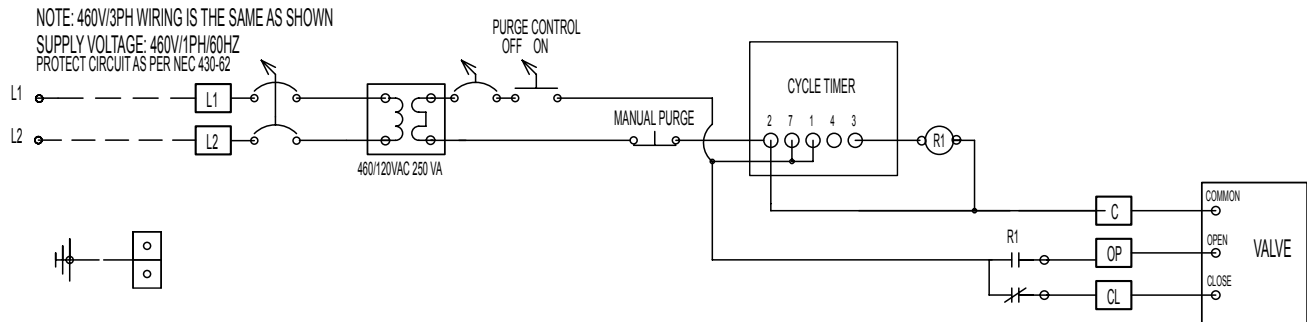

## CYC WIRING DIAGRAM WITH MBVSR VALVE (460V/1PH Auto Purge Systems Only)

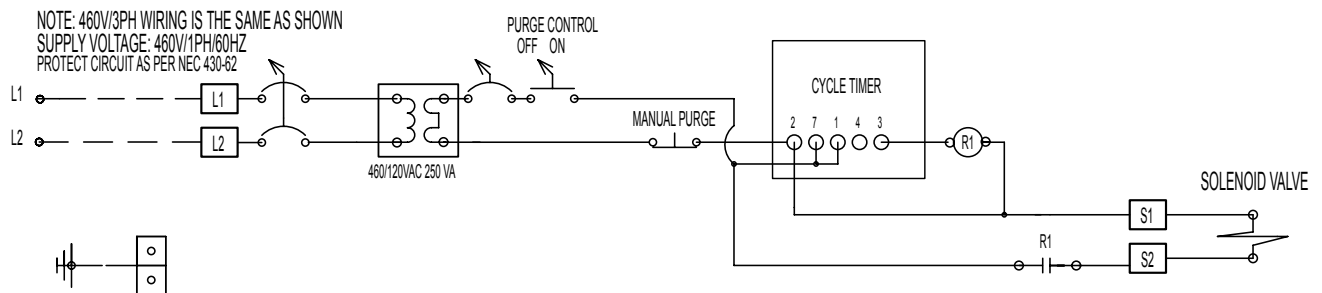

## CYC WIRING DIAGRAM WITH MBVFS VALVE (460V/1PH Auto Purge Systems Only)

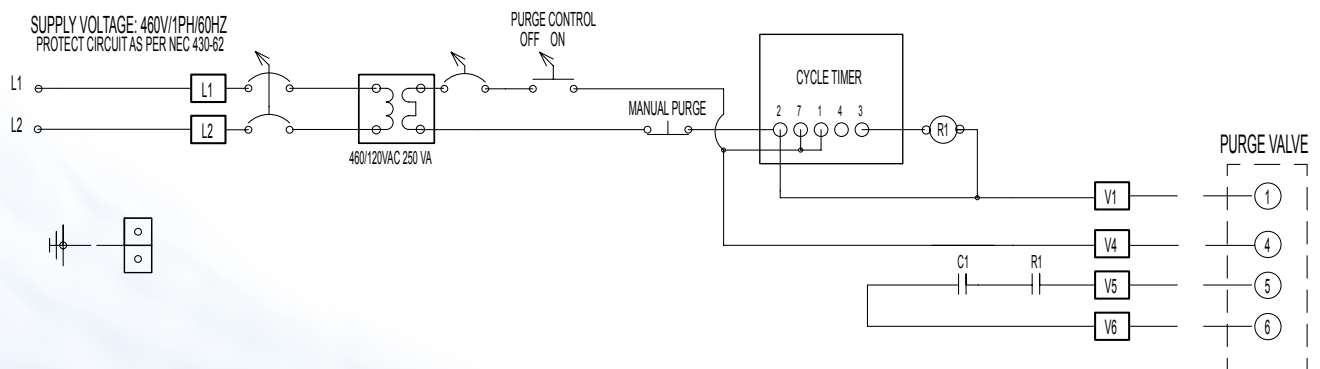

## CYC WIRING DIAGRAM WITH MBV VALVE (575V/1PH Auto Purge Systems Only)

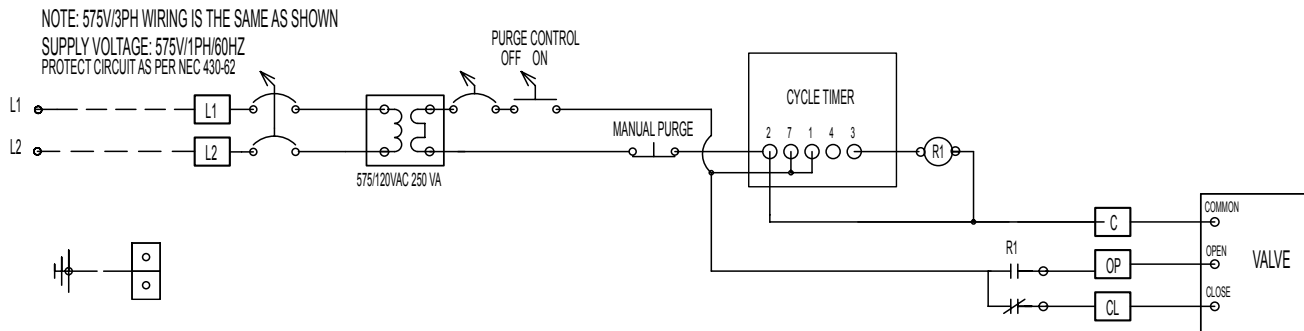

## CYC WIRING DIAGRAM WITH MBVSR VALVE (575V/1PH Auto Purge Systems Only)

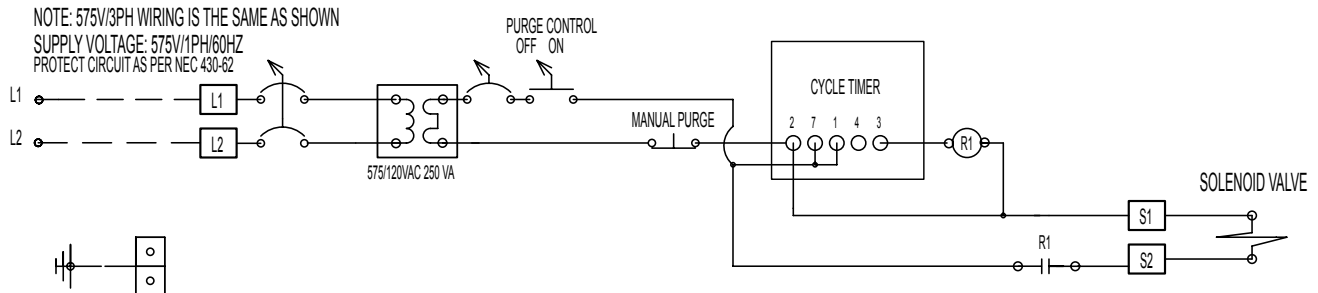

## CYC WIRING DIAGRAM WITH MBVFS VALVE (575V/1PH Auto Purge Systems Only)

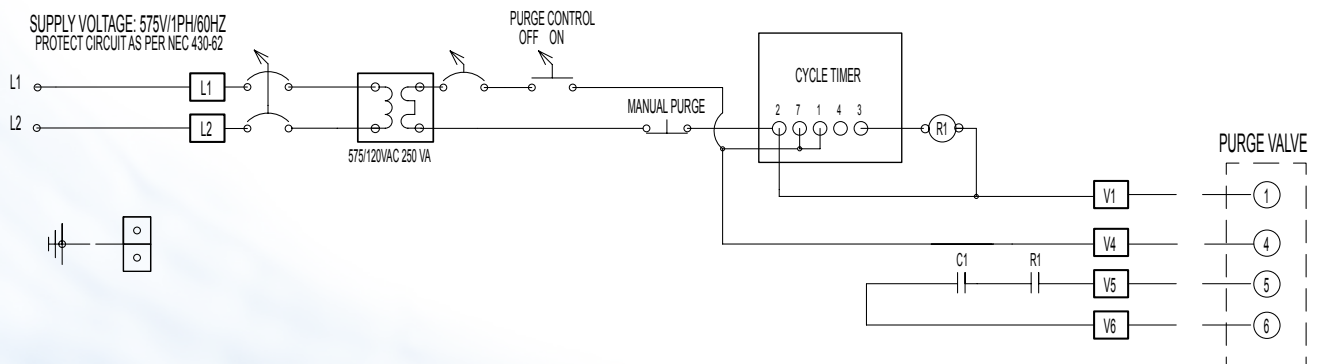

## TROUBLE SHOOTING VALVES with CYC TIMER

1. If the valve won't open, then check the following:

**FOR MBV, MBVFS, AND MBVSR VALVES:**

- a. Check voltage to the CYC. Check for 115VAC at the 8-pin socket terminal 2 & 7. Check primary/secondary voltage and continuity on fuses or circuit breakers on transformer.
- b. Check voltage to MBVSR. Check 115VAC voltage at panel terminal S1 & S2 after pressing "MANUAL PURGE" push button. Voltage drop should not exceed more than 10%. If voltage is adequate, then check the relay.
- c. Check voltage to MBV. Check 115VAC voltage at panel terminal C & OP after pressing "MANUAL PURGE" push button. Voltage drop should not exceed more than 10%. If voltage is adequate, then view the stem on top. If it does not rotate clockwise after pressing the "MANUAL PURGE" push button, then check the relay. If relay is good then replace the motorized ball valve.
- d. Check voltage to MBVFS. Check 115VAC voltage at panel terminal S1 & S2 after pressing "MANUAL PURGE" push button. Voltage drop should not exceed more than 10%. If voltage is adequate, then the stem on top. If it does not rotate clockwise after pressing the "MANUAL PURGE" push button, then check the relay. If relay is good then replace the valve.

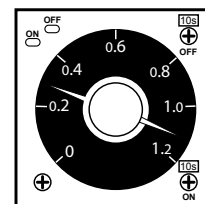

**CYC TIMER**

2. If the valve won't close then check the following:

**FOR MBV, MBVFS, and MBVSR Valves:**

- a. Check voltage to the CYC. Check for 115 VAC at the 8-pin socket terminal 2 & 7. Check primary/secondary voltage and continuity on fuses or circuit breakers on transformer.
- b. Check voltage to MBVSR. No voltage should be present at panel terminal S1 & S2 during "OFF" period. If voltage is present during "OFF" period, then review "Valve Operation with CYC" "ON" and "OFF" setting. If settings are correct, then check 8-pin socket at terminal 1 & 3. If voltage is present then replace timer. If voltage is not present, then check relay.
- c. Check voltage to MBV. Check 115VAC voltage at panel terminal C & CL during "OFF" period. Voltage drop should not exceed more than 10%. If voltage is adequate, then view the stem on top of the valve and check the CYC "ON" and "OFF" settings. If it does not rotate clockwise after pressing "MANUAL PURGE" push button, then check the CYC settings. If settings are correct, then check 8-pin socket at terminal 1 & 3. If voltage is present during "OFF" period, then check relay. Stem must be perpendicular to the flow in the close position. If not, then replace the motorized ball valve.
- d. Check voltage to the MBVFS. Check 115VAC voltage at panel terminal V1 & V4 after pressing "MANUAL PURGE" push button. Voltage drop should not exceed more than 10%. If voltage is adequate, then view the stem on top of the valve and check the CYC "ON" and "OFF" settings. If it does not rotate clockwise after pressing "MANUAL PURGE" push button, then check CYC settings. If settings are correct, then check 8-pin socket at terminal 1 & 3. If voltage is present during "OFF" period, then check relay. Stem must be perpendicular to the flow in the close position. Allow battery pack on the MBVFS to charge for 24 hours before using valve. If valve still does not close after a full charge, then replace it.



**MBV VALVE**

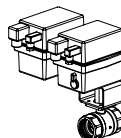

**MBVFS VALVE**

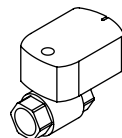

**MBVSR VALVE**