

Series BM (Back Mount) & FM (Foot Mount) Mounting Kits

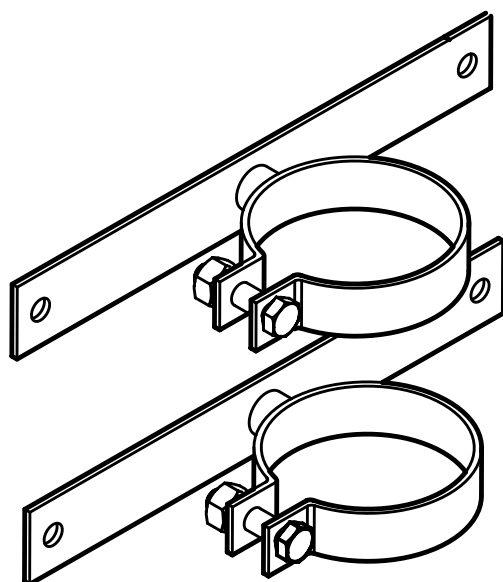

BACK MOUNT

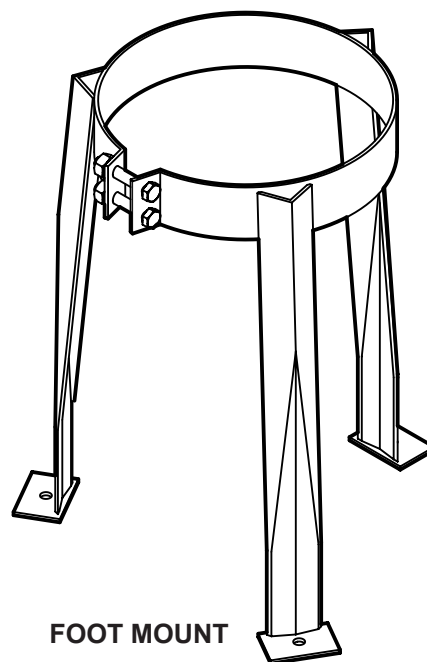

FOOT MOUNT

DESCRIPTION:

Backmount Kit (BM Series): The Backmount kit allows the installation of separators Series .5T thru 3T₁ to be installed onto a wall. The kit includes two (2) bolt-on brackets which mount to the separator by clamping to the separator body. The brackets are lag bolted to a wall.

Footmount Kit (FM Series): The Footmount kit allows installation of a separator as a “free standing” unit. The footpads have holes for mounting. Footmount Kits are available for Series .5T thru 3T₂.

SPECIFICATIONS:

	MATERIAL	FINISH	HARDWARE
BACKMOUNT KIT	Carbon Steel	Powder Coated Blue	Clamping Bolt (Plated Steel)
FOOTMOUNT KIT		Blue Enamel	

NOTE: Lag bolts for BM or FM Series are not included.

SIZING GUIDELINES:

SEPARATOR SIZE	.5T	.75T	1T	1.2T	1.5T	2T	2.5T	3T
BACKMOUNT KIT	BM-3		BM-4A	BM-4	BM-5		BM-6	BM-8
FOOTMOUNT KIT		FM-4	FM-5	FM-4	FM-5		FM-6	FM-8

1. Not available on the following separators: 3T-FLA, 3T-FLG, 3T-RDF and 3T-RDT.